

The MPS 2D is the most versatile of our very successful range of automatic profile stitching machines. It provides all the benefits of the MPS D (speed, quality, unskilled operator etc.) but, in addition, it is a larger machine that has an extremely versatile control system and an independently driven side knife. These features ensure that almost any component, from tiny pocket flaps up to jacket/raincoat fronts, can be sewn in the fastest and most controlled manor. The independently driven side knife enables fast turning of collar and jacket corners, whilst trimming the cloth with no risk of cloth damage.

- Durkopp 272-740142 lockstitch sewing head with underbed trimmer and independently driven side knife to ensure perfect cloth trimming even at difficult corners.
- Efka single phase DC sewing motor with electronic speed control.
- Powerful, dedicated PLC designed to provide many program options to suit any style of jig, whilst also being extremely user-friendly.
- Proven intermittent template feeding mechanism for perfect stitching.
- Photocell detection of tapes on template for precise control of start and stop position, corners and the amount of condensed stitches.
- Knife delay option.
- Turn arm to assist in rotating large jigs at the corner. Table extension and air floatation option for large templates (jacket fronts etc.).

SPECIFICATIONS

Sewing head	Durkopp 272-740142 with underbed thread trimmer and motor driven side knife.
Sewing motor	Efka single phase DC.
Sewing speed	To 2600 stitches per minute.
Electricity supply	Single phase 220-240 Volts.
Air supply	Pressure – 6 bar./Consumption – 1.5 metre cubed/hour.
Weight	Net – 160kg./Shipping – 200kg.
Table height	910mm
Production	Up to 3000 cuffs/8 hours depending on handling efficiency. Up to 1550 blouse collars/8 hours depending upon handling efficiency.

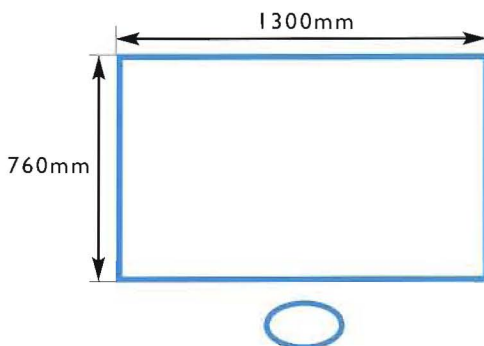
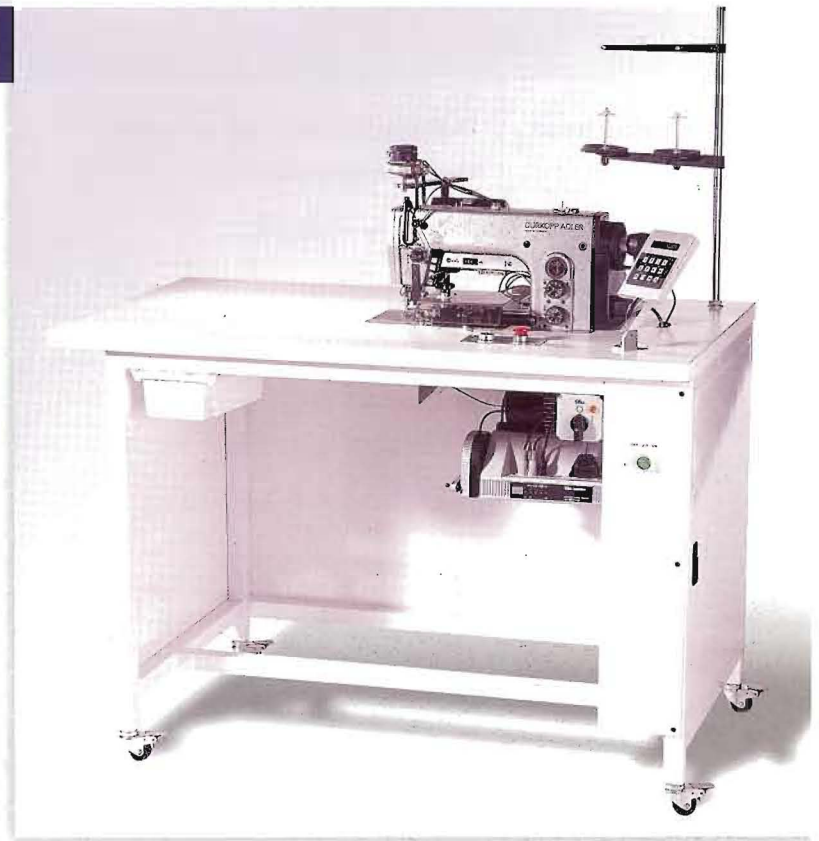

MMS UK

1 Southview Business Park, Ghyll Royd, Guiseley,
LEEDS LS20 9LT, England

Tel. 0044 (0) 1943 884334

Fax. 0044 (0) 1943 884335